

# Tegman (PTY) LTD



## BEATER BARS



Durban / Ballito / Gauteng / Nelspruit / Cape Town

[www.tegman.co.za](http://www.tegman.co.za)

# BEATER BARS

Beater bars play a crucial role in preventing screens from blinding or pegging in various material screening processes.

Blinding occurs when fine, sticky, or moist materials clog screen openings, reducing efficiency.  
Pegging happens when larger particles lodge in screen holes, disrupting proper classification.

Beater bars help reduce these issues by agitating the screen surface, dislodging trapped material, and ensuring continuous flow. They create vibrations or impact forces that break up clumps and keep the screen mesh clear.

This is particularly beneficial in industries like mining (on both mobile and static screens) aggregate processing, and recycling, where maintaining optimal screening performance is essential for productivity

Tegman manufactures Beater Bars that can connect and fit any desired length.

## Beater Bar Application & Fixing:

The Fixing Rod, which forms part of the modular Beater Bar assembly, is secured to the back plate on the feed side of the screening machine. The Beater Bars are designed for use with various screen types, including wire mesh and PU screens, as illustrated in the accompanying images.

### IMAGE 'B':

Beater Bar Fixing Rod attached to back plate of a PU Screen

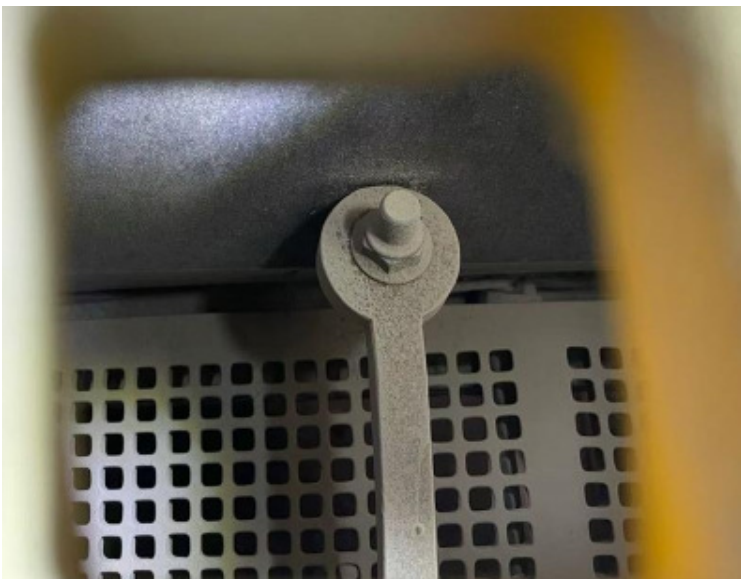

BEATER BAR – PU SCREEN

### IMAGE 'A':

Two Rows (modular) Beater Bars, running parallel. Fixed with Joiner Rods (to ensure that the beater bars stay in place), sitting on top of a Wire Mesh Screen.

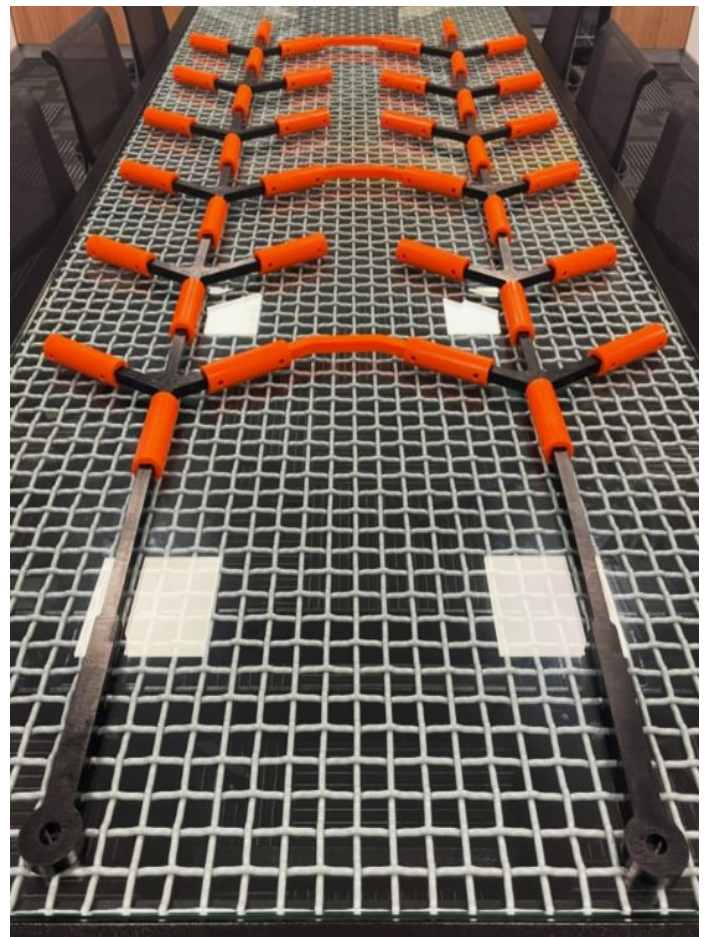

BEATER BAR – WIRE MESH SCREEN

**Modular Beater Bar System**

Our beater bar system is fully modular, allowing you to build exactly the length you require.

Sections connect with a simple pin for fast assembly, removal, or replacement.

Run a single row, double row, or as many rows as your application requires.

Cover only the areas affected by pegging or blinding, or fit the full deck — the choice is yours.

Quick. Flexible. Built for optimal screening performance.

FIXING ROD



MODULAR T-SECTION

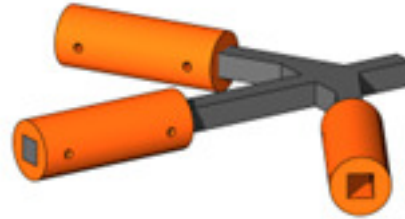

**MODULAR CONFIGURATION EXAMPLES**

1 Modular T-Section

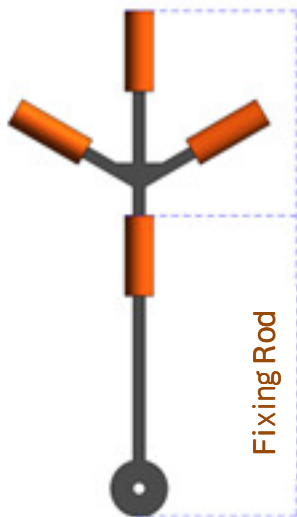

Fixing Rod

2 Modular T-Section

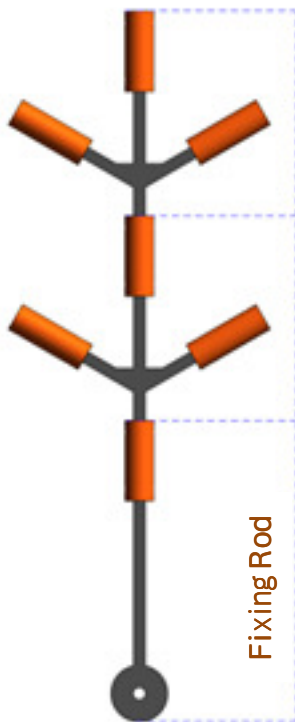

Fixing Rod

3 Modular T-Section

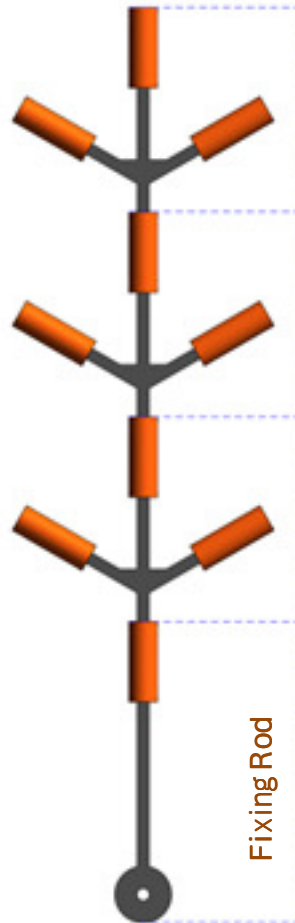

Fixing Rod



### BEATER BAR COVERAGE :

Precision coverage, quick assembly, and maximum screening efficiency.

- **Flexible Coverage**

Choose 100%, 75%, 50%, or 25% screen coverage to target pegging and blinding where it happens most.

- **Quick Assembly**

Modular sections connect with a simple pin & (when required) joining rods, for fast adding, removing, or replacing.

- **Custom Fit**

Easily adjust the length to suit any deck configuration for optimal performance.

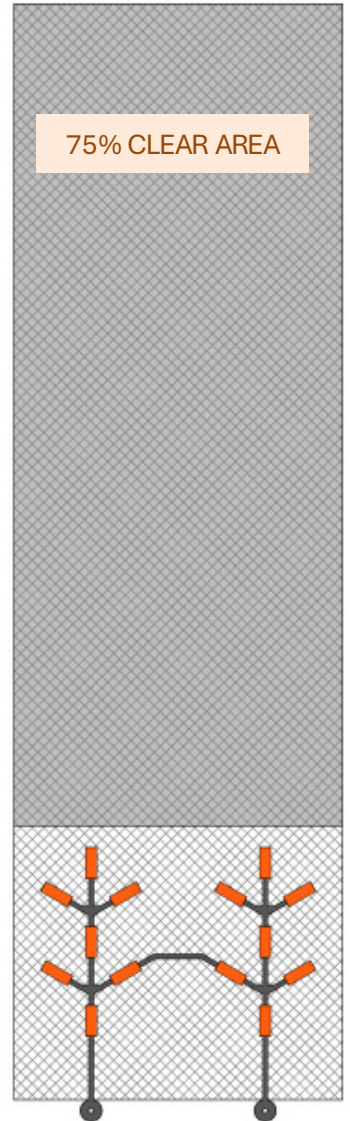
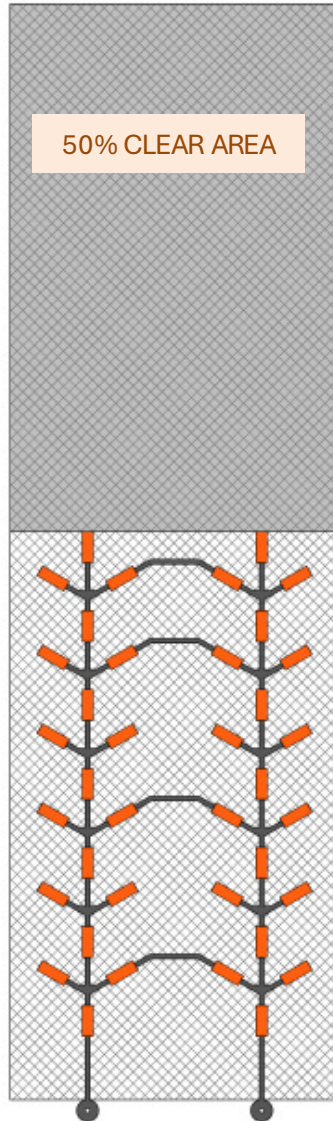
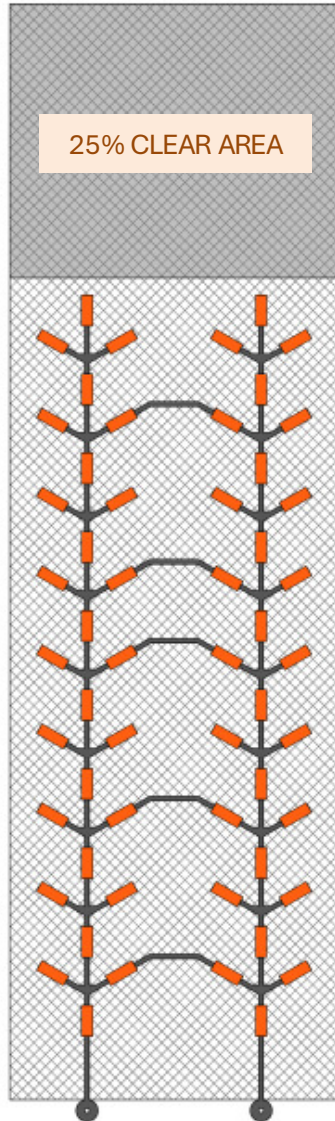
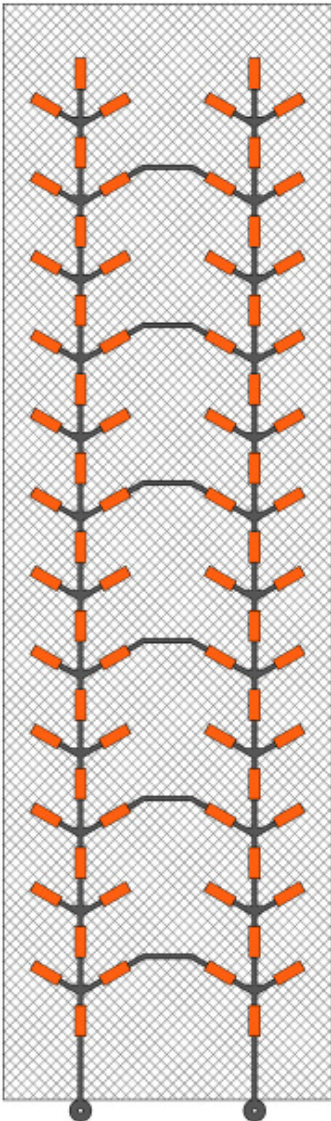

### Customizable Beater Bar Layouts:

As shown in the example diagram below, beater bars can be configured in multiple rows to suit your processing needs & machine type. Using fixing rods and joining pins, sections can be quickly added, removed, or adjusted, offering a flexible, hassle-free setup.

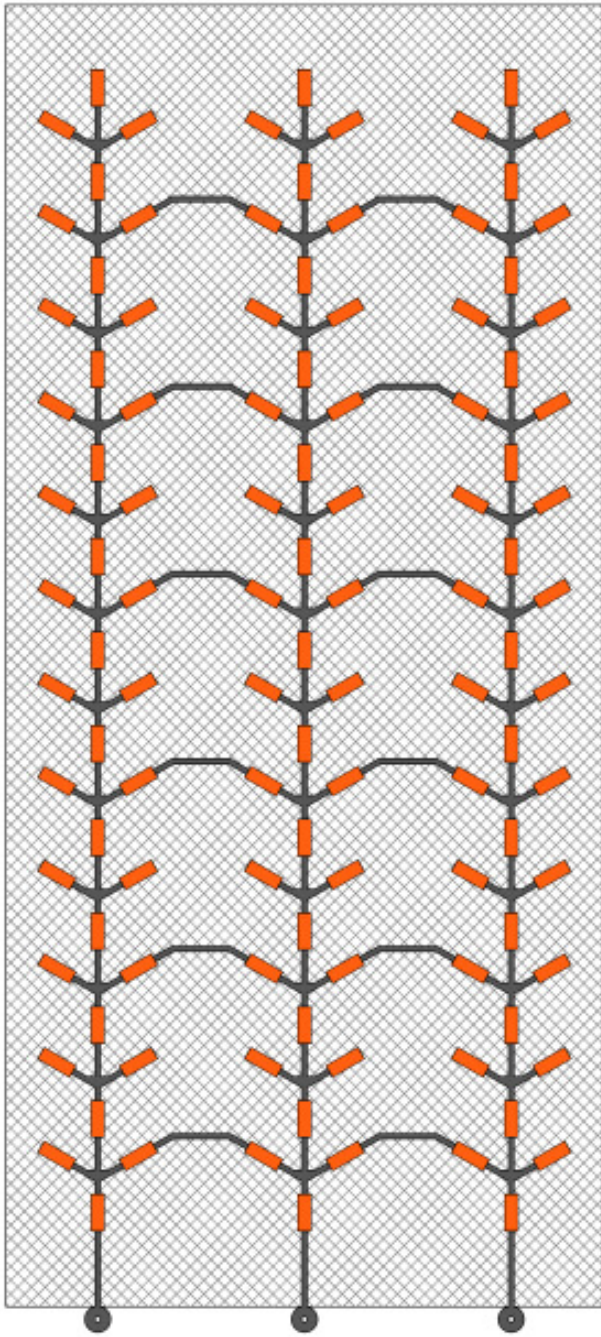

3 ROWS

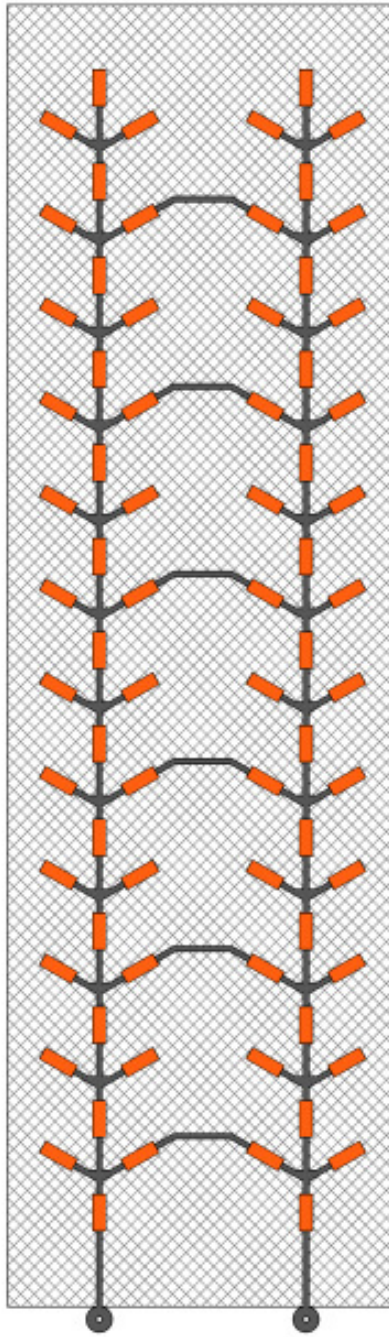

2 ROWS

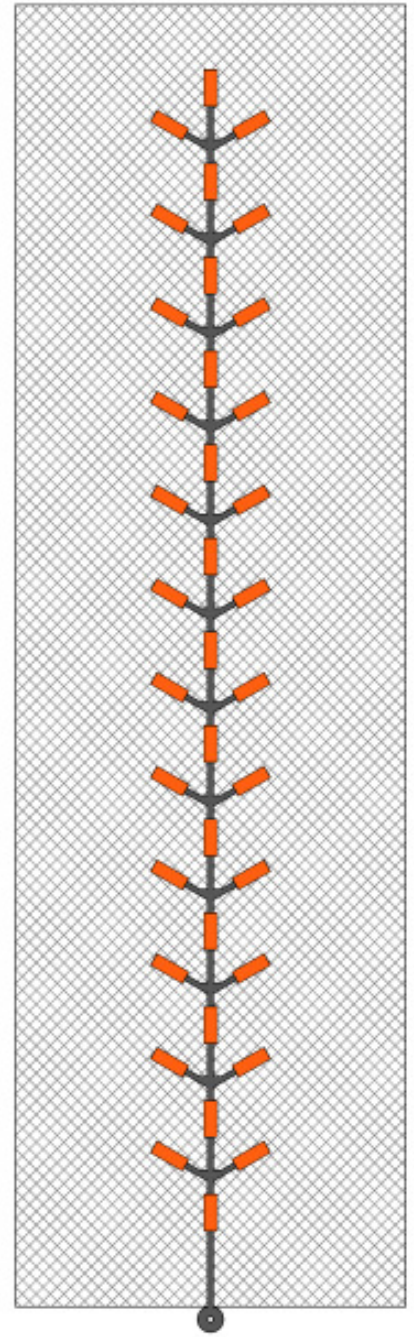

1 ROW

**DECK CLEARANCE :**

Beater Bars shall be installed on the bottom deck of the screening machine.

A minimum clearance of 200 mm must be maintained between the top surface of the bottom deck and the underside of the deck above to ensure Beater Bars operates effectively.

Min. 200mm clearance

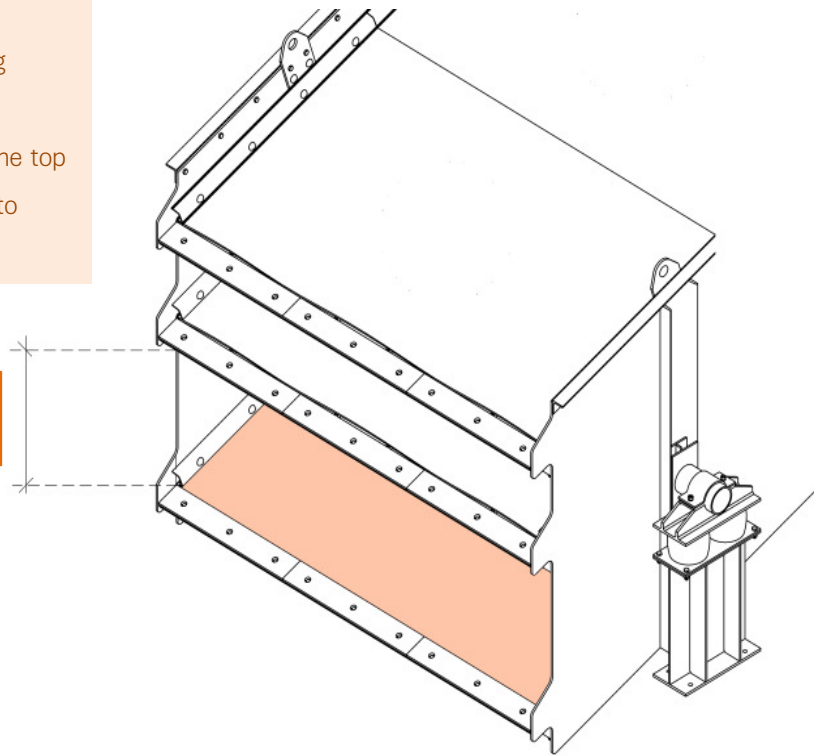

VIBRATING MACHING – BEATER BAR TO BE FIXED TO BOTTOM SCREEN



# Tegman



## GET IN TOUCH

### **GAUTENG BRANCH & FACTORY**

Cell: 067 008 5354

### **NELSPRUIT BRANCH**

Cell: 068 533 4089

### **CAPE TOWN BRANCH**

Cell: 066 298 9523

### **DURBAN BRANCH & FACTORY**

031 563 4252 / 072 299 4947 / 065 817 1415

### **UMHLALI CORPORATE HEAD OFFICE**

Cell: 065 810 2138

